

HYDRAULIKAGGREGAT H-SF 3

M 1501 478 E-DE-02/2020

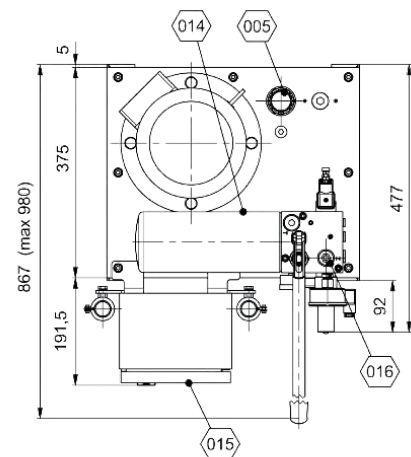
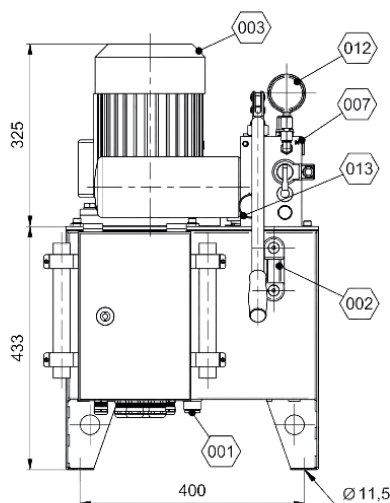
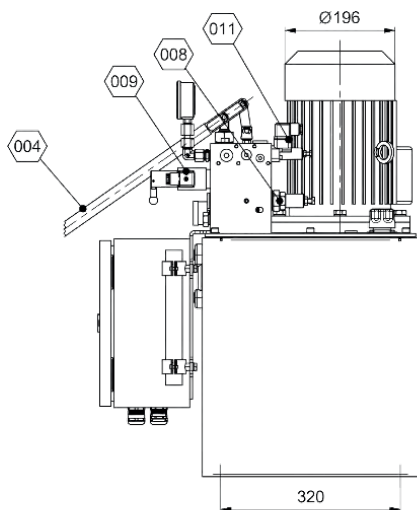
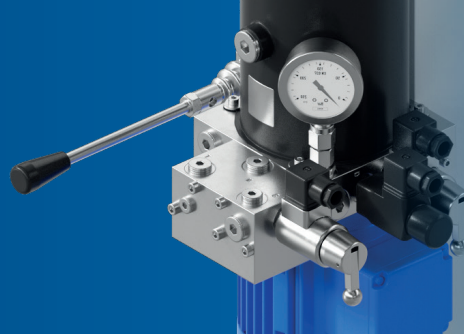

TECHNISCHE DATEN

Typ		V3A	V3B	V3C	V3D	V3E
Lüftdruck [bar]		80	120	175	145	55
Druckbegrenzungsventil [bar]		110	150	205	175	85
Druckschalter [bar]	min.	80	120	175	145	55
	max.	95	135	190	160	70
Pumpenleistung [l/min]		20	13	9	9	20
Hydraulikflüssigkeit nach DIN 51524- T2 (Standardausführung)		HLP Synth 15 (Temperaturbereich -25 °C - +30 °C) HLP Synth 30 (Temperaturbereich -15 °C - +50 °C)				
Motor		3 kW; 1425 min ⁻¹ ; 3x400 V; 50 Hz; 6,7 A				
Ventilspannung	P	24 V DC 30 W				
	V	110 V AC 50/ 60 Hz 30 W				
	W	230 V AC 50/ 60 Hz 30 W				
Ventilleistung	EM 41S	160 l/min bei Δp = 8 bar				
	EM 21S	40 l/min bei Δp = 9 bar				
Tankvolumen [l]		30				
Umgebungstemperaturbereich	- Standardausführung	-25 °C - +50 °C				
	L Tieftemperaturausführung	-40 °C - +30 °C				
	T Hochtemperaturausführung	-15 °C - +75 °C				
max. Anzahl Betätigungen pro Stunde [c/h]		90				
Schutzklasse		IP 55				
Gewicht ohne Ölfüllung [kg]		ca. 71				



HYDRAULIKAGGREGAT H-SF 3

M 1501 478 E-DE-02/2020

OPTIONEN

- Hoch- und Tieftemperaturausführung
- Edelstahlausführung
- Klemmkasten
- Niveau- und Temperaturschalter
- Parallelventil

HYDRAULIKPLAN

