

# HYDRAULIC POWER UNIT H-SF 3

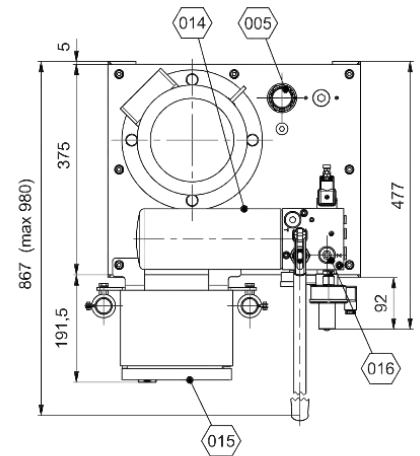

M 1501 478 E-EN-02/2020

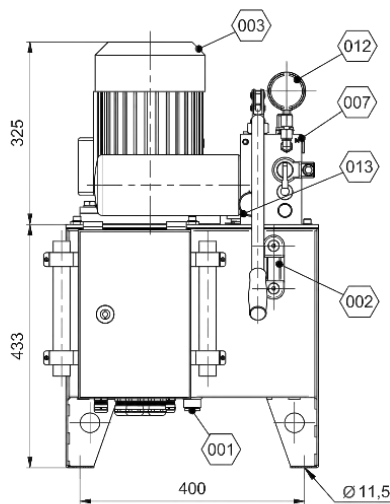
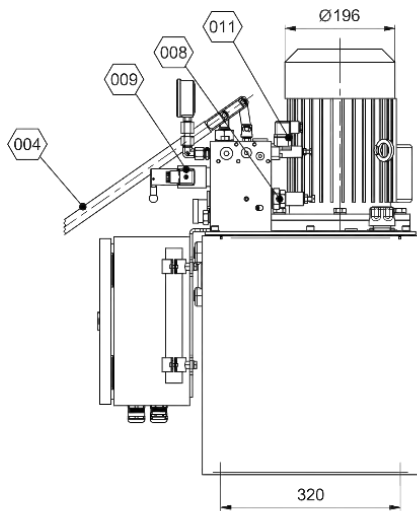

## TECHNICAL DATA

TYPE		V3A	V3B	V3C	V3D	V3E
Release pressure [bar]		80	120	175	145	55
Pressure relieve valve setting [bar]		110	150	205	175	85
Pressure switch [bar]	min.	80	120	175	145	55
	max.	95	135	190	160	70
Pump capacity [l/min]		20	13	9	9	20
Operating fluid acc. DIN 51524- T2 (standard version)		HLP Synth 15 (ambient temp. range -25 °C - +30 °C) HLP Synth 30 (ambient temp. range -15 °C - +50 °C)				
Motor		3 kW; 1425 min-1; 3x400 V; 50 Hz; 6,7 A				
Valve voltage	P	24 V DC 30 W				
	V	110 V AC 50/ 60 Hz 30 W				
	W	230 V AC 50/ 60 Hz 30 W				
Valve capacity	EM 41S	160 l/min at $\Delta p = 8$ bar				
	EM 21S	40 l/min at $\Delta p = 9$ bar				
Tank volume [l]		30				
Ambient temperature ranges	- Standard version	-25 °C - +50 °C				
	L low temperature	-40 °C - +30 °C				
	T high temperature	-15 °C - +75 °C				
Max. no. of operating cycles [c/h]		90				
Protection class		IP 55				
Weight without oil-filling [kg]		approx. 71				



# HYDRAULIC POWER UNIT H-SF 3

M 1501 478 E-EN-02/2020

## OPTIONS

- High and low temperature version
- Stainless steel version
- Terminal box
- Level and temperature switch
- Parallel valve

## HYDRAULIC SCHEME

