

TROMMELBREMSE SBH

M 500 6500 E-DE-2017-05

nach DIN 15435 | mit externer Bremsfeder und elektro-
hydraulischem Lüftgerät

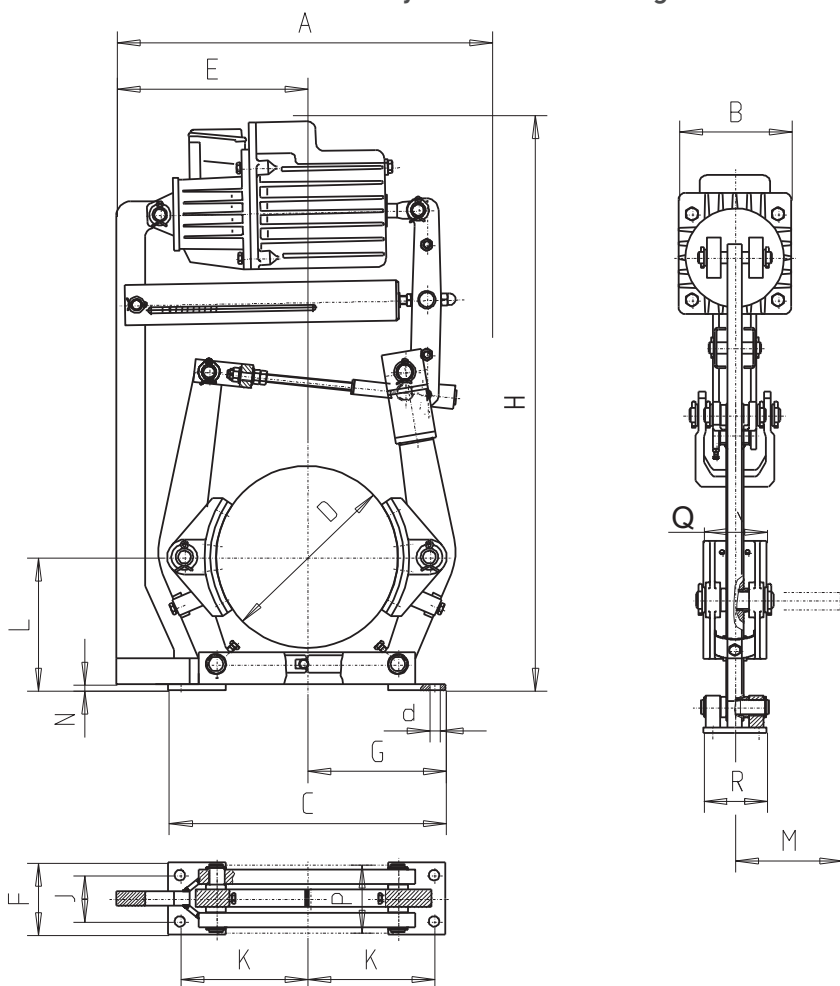

BEI BESTELLUNG BITTE ANGEBEN:

- Bremsentyp und Lüftgerät, z.B. TE 250/30/5
- Anschlussspannung des Lüftgeräts
- mit oder ohne Verschleißnachstellung
- Zubehör

Lüftgerät Typen

1 = Ed 23/5	10 = EB 220-50
2 = Ed 30/5	20 = EB 300-50
3 = Ed 50/6	30 = EB 500-60
4 = Ed 80/6	40 = EB 800-60
5 = Ed 121/6	50 = EB 1250-60

Bremsentyp	Lüftgerät Größe	Bremsmoment in Nm bei $\mu = 0,4$	A	B	C	D	E	F	G	H	J	K	L	M	N	P	Q	R	d	kg*
SBH 200	1 / 10	50 - 325	520	160	320	200	270	90	160	750	55	145	160	130	10	75	70	96	14	28
	2 / 20	50 - 425	160																	
SBH 250	1 / 10	50 - 325	530	160	400	250	284	110	200	870	65	180	190	155	10	95	90	113	18	40
	2 / 20	50 - 425	530	160						870										
	3 / 30	50 - 850	570	195						910										
SBH 315	1 / 10	50 - 475	640	160	480	315	330	125	240	965	80	220	230	185	15	118	110	135	18	52
	2 / 20	50 - 600	640	160						965										
	3 / 30	150 - 1200	650	195						995										
	4 / 40	150 - 1950	650	195						995										
SBH 400	2 / 20	150 - 600	760	160	600	400	407	160	300	1050	100	270	280	230	15	150	140	167	22	82
	3 / 30	150 - 1200	760	195						1085										
	4 / 40	150 - 1950	760	195						1085										
	5 / 50	150 - 2250	840	240						1095										
SBH 500	3 / 30	400 - 1420	900	195	710	500	490	190	355	1330	130	325	340	285	13	190	180	190	22	130
	4 / 40	400 - 2300	900	195						1330										
	5 / 50	400 - 3400	900	240						1330										
	6 / 60	400 - 5700	900	240						1330										

* Kg ohne Lüftgerät