

# CALIPER BRAKE

## SHI 100 FC with console

M 1501 295 E-EN-2016-12

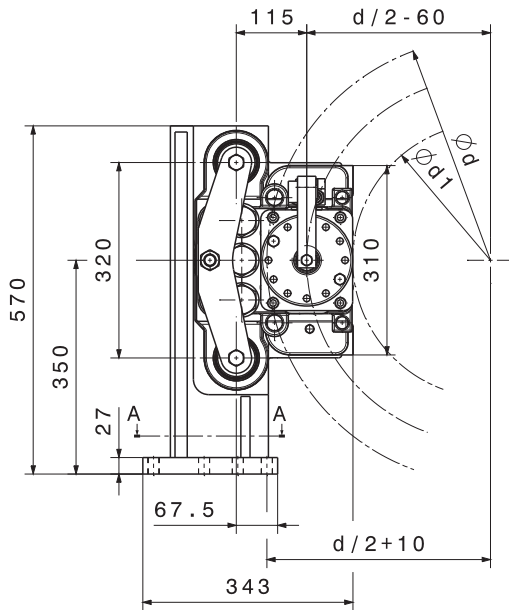

hydraulic connection M16x1,5

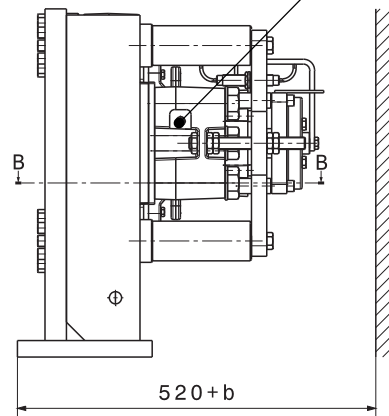

Schnitt A-A section

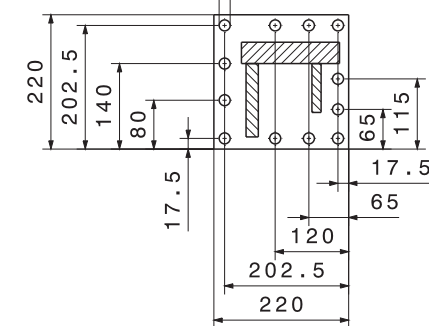

Schnitt B-B section

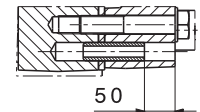

manual release device is optionally available

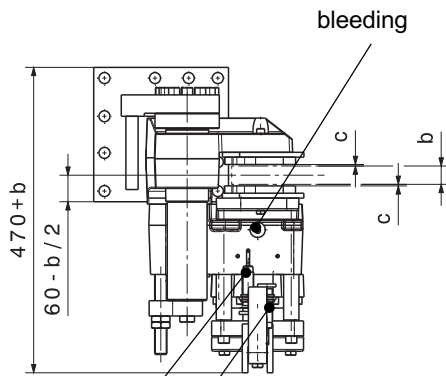

optional: proximity switch "lining wear"

optional: proximity switch "brake open/ close"

SHI-Type		1	2	3	4	5	6	7	
<b>Clamping Force <math>F_A</math></b>									
$F_A$	with airgap $c = 1,0 \text{ mm}$	kN	28,0	43,7	52,2	68,7	77,0	98,0	115,0
$F_A$	with airgap $c = 1,5 \text{ mm}$	kN	27,0	41,3	48,8	62,7	74,4	88,0	94,0
<b>Torque Calculation</b>									
$M_{Br}$	braking torque	Nm	2 x $F_A \times \mu \times (d/2-60)$						
<b>Hydraulic</b>									
PL	release pressure	bar	35	50	60	80	95	145	175
$P_{max}$	max. pressure	bar	110	110	110	110	150	175	205
$V_{max}$	volume at $c = 1,5 \text{ mm}$	ltr	0,034						
<b>Brake Discs</b>									
b	disc thickness	mm	20 ≤ b ≤ 40						
d	disc-Ø	mm	650 ≤ d ≤ 3000						
$d_1$	max. hub or drum-Ø	mm	d-280 mm						
<b>Dimensions</b>									
L x B x H = 343 x (470+b) x 570 mm									
max. weight: 180 kgs									

Mounting Studs					
Type SHI FC		101 - 103	104 - 105	106 - 107	
n	quantity	12	12	12	
	size, grade	M16, 12.9	M16, 12.9	M16, 12.9	
$M_A$	fastening torque	Nm	355 at $\mu = 0,14$	355 at $\mu = 0,14$	355 at $\mu = 0,14$
Linings					
	material	sinter			
	friction coefficient*	0,4			

\*average friction coefficient with standard material combination and a circumferential speed up to 15 m/s

When ordering please advise: right hand version, as shown; left hand version, mirror inverted!