

HUB WITH BOLTED DISC

M 1501 315 E-EN-2005-08

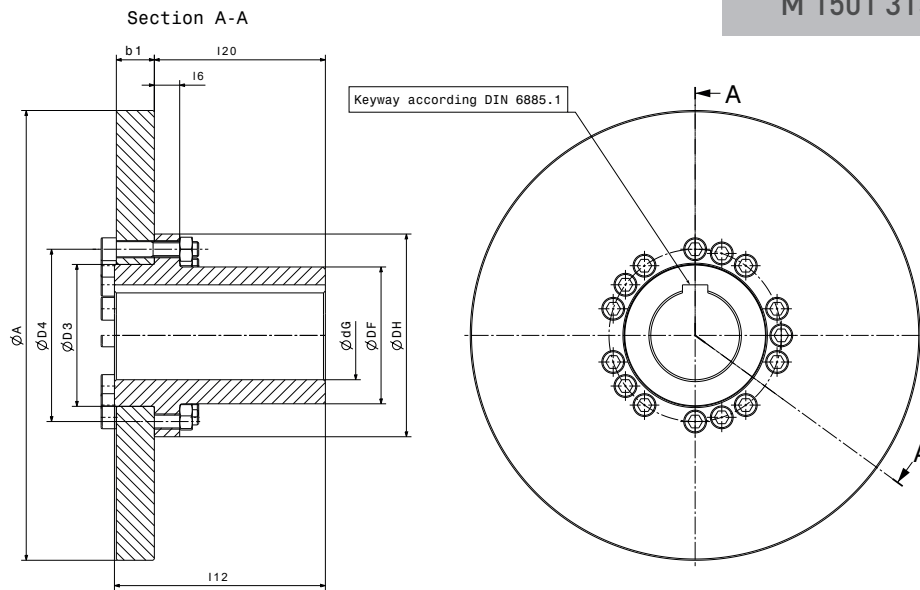

Type of Hub		N 1800	N 3800	N 9000	N 17000	N 24000	N 39000	
max. braking torque of hub	Nm	1800	3800	9000	17000	24000	39000	
max. rpm	1/min	4000	3200	2600	2000	1800	1400	
ØdG	max. final bore	mm	65	75	100	125	165	190
	Ø DF _{h9}	mm	92	108	140	176	235	270
	Ø DH	mm	135	160	200	255	320	370
	Ø D3 _{H7/h6}	mm	96	112	145	180	245	280
	Ø D4	mm	116	136	172	218	282	325
	l6	mm	15	20	20	25	30	34
	l12	mm	166	166,5	206,5	212	252,5	252,5
	l20	mm	135	135	175	180	220	220
n cylinder bolts DIN 912-10.9	pcs	12xM10x60	15xM12x65	15xM16x70	15xM20x80	15xM20x90	15xM24x100	
bolt tightening torque	Nm	69	120	295	580	580	1000	

Brake Disc Ø A x b1		Weight & Inertia					
Ø 315 x 30	kg	21,5					
	Kgm ²	0,231					
Ø 355 x 30	kg	26,5					
	Kgm ²	0,370					
Ø 400 x 30	kg	32,8	34,4	39,2			
	Kgm ²	0,594	0,597	0,600			
Ø 450 x 30	kg	40,6	42,2	46,8			
	Kgm ²	0,947	0,948	0,969			
Ø 500 x 30	kg		51,0	55,6	63,2		
	Kgm ²		1,442	1,460	1,542		
Ø 560 x 30	kg		62,8	67,4	74,7		
	Kgm ²		2,267	2,282	2,348		
Ø 630 x 30	kg			82,8	90,0	112,4	
	Kgm ²			3,640	3,700	4,077	
Ø 710 x 30	kg			102,6	109,9	132,2	144,8
	Kgm ²			5,857	5,892	6,287	6,655
Ø 800 x 30	kg				135,1	157,4	169,9
	Kgm ²				9,481	9,859	10,208