

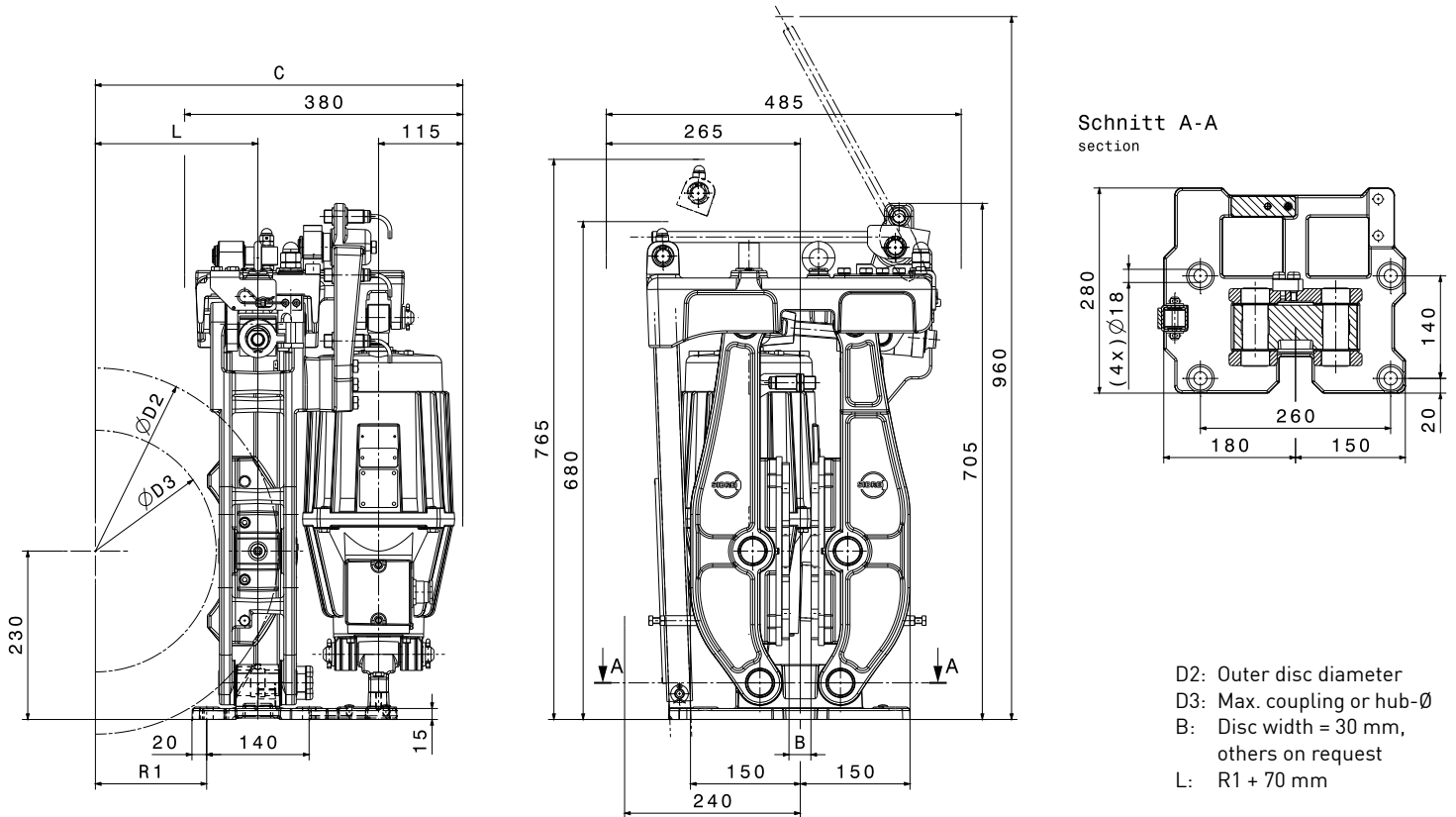

# DISC BRAKE USB5-I - ELHY

M 1501 460 E-EN-2019-05



D2: Outer disc diameter  
 D3: Max. coupling or hub-Ø  
 B: Disc width = 30 mm, others on request  
 L: R1 + 70 mm

Thruster type				300/5		500/6		800/6	
Dimensions in mm				Braking torque M in Nm					
D2	D3	R1	C	Mmin	Mmax	Mmin	Mmax	Mmin	Mmax
355	180	75.5	425.5	550	850	650	1400	900	2200
400	230	102	452	650	950	750	1600	1000	2600
450	280	127	477	750	1100	900	1900	1200	3000
500	330	152	502	850	1200	1000	2100	1300	3400
560	390	182	532	1000	1400	1100	2400	1500	3900
630	450	217	567	1100	1600	1300	2800	1700	4400
710	530	257	607	1300	1900	1500	3200	2000	5100

- Brake linings of sintered material with standard brake disc material S355J2G3
- The specified braking torques are based on an average friction coefficient  $\mu = 0,4$  with grinded and optimum conditioned brake linings up to a sliding speed of 60 m/s. Deviating parameters can reduce the friction-coefficient.
- Please contact us when using thrusters with lifting- and/ or lowering valves.
- Weight without thruster: 85 kg.
- **Available options:**
  - Special executions for low and high ambient temperature
  - Manual release
  - Inductive sensors for indication "brake open", "brake closed" and/ or "pad wear".
  - Temperature sensor for brake linings
  - Load cell for monitoring of clamping force