

# DRUM BRAKE

## THi



M 900 1200 E-EN-2001-08

acc. to DIN 15435 | spring applied, thruster released

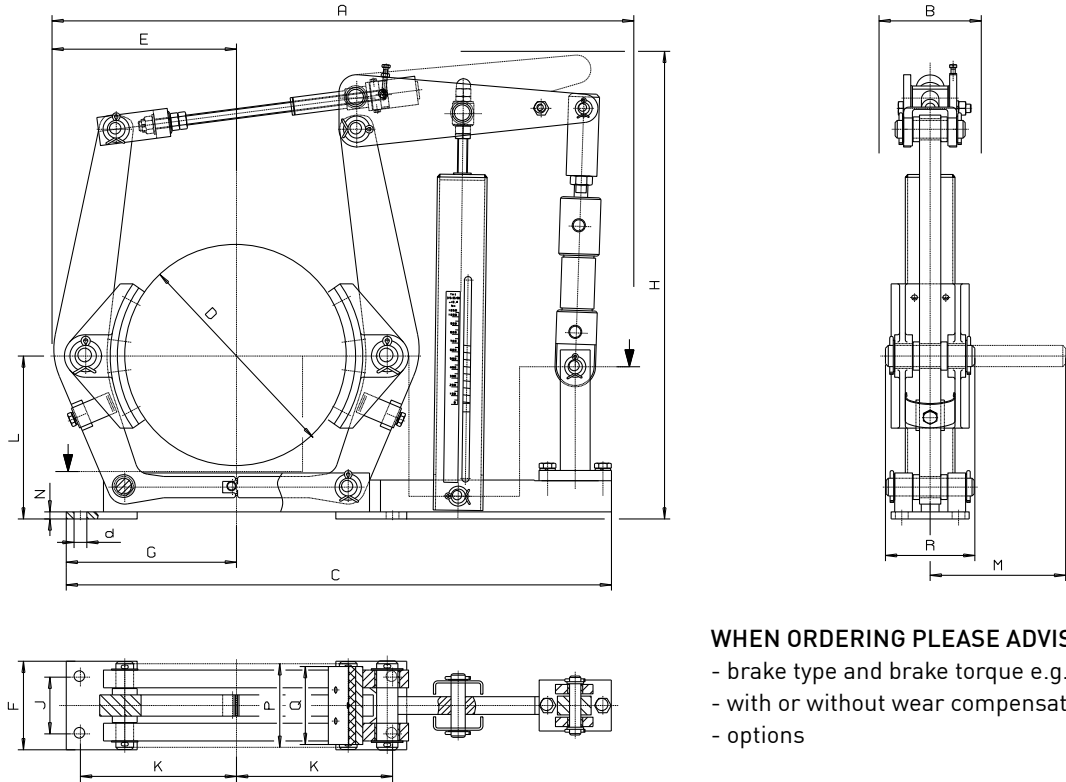

**WHEN ORDERING PLEASE ADVISE:**

- brake type and brake torque e.g. THi 200-50-300
- with or without wear compensation
- options

Necessary volume flow: 8 l / min.

BRAKE-TYPE	Requested PRESSURE [bar]	MBR. (Nm) TORQUE $\mu = 0,4$	A	B	C	D	E	F	G	H	J	K	L	M	N	P	Q	R	d	kg*
THi 200	6	50 - 300	535	95	515	200	170	90	160	475	55	145	160	115	10	75	70	96	14	19
	10	85 - 400	540	95						475										
THi 250	6	40 - 325	660	110	625	250	210	110	200	550	65	180	190	133	10	95	90	113	18	30
	10	40 - 450	660	110						550										
	15	100 - 850	665	110						560										
THi 315	6	70 - 420	780	130	735	315	260	125	240	650	80	220	230	160	10	118	110	135	18	50
	10	70 - 550	780	130						650										
	15	75 - 1050	785	130						660										
	20	90 - 1700	790	130						660										
THi 400	10	80 - 575	935	160	900	400	310	160	300	765	100	270	280	199	12	150	140	167	22	85
	15	100 - 1100	940	160						775										
	20	100 - 1800	945	160						775										
	30	125 - 2750	955	160																
THi 500	15	200 - 1400	1090	200	1025	500	385	190	355	870	130	325	340	242	13	190	180	202	22	130
	20	200 - 2200	1095	200						870										
	30	200 - 3400	1100	200						870										
	50	200 - 5400	1110	200						870										
	30	500 - 3300	1245	240						1000										
THi 630	50	500 - 5500	1250	240	1190	630	465	250	440	1000	170	400	420	295	15	236	225	244	27	206
	70	500 - 8200	1260	240						1000										
THi 710	30	500 - 3800	1385	260	1302	710	525	270	490	1100	190	450	470	332	15	265	255	276	27	268
	50	500 - 6300	1390	260						1100										
	70	500 - 9400	1400	260						1100										

\* kg without thruster