

DRUM BRAKE

SBG

M 500 5000 E-EN-2007-01

acc. to DIN 15435 | spring applied, thruster released

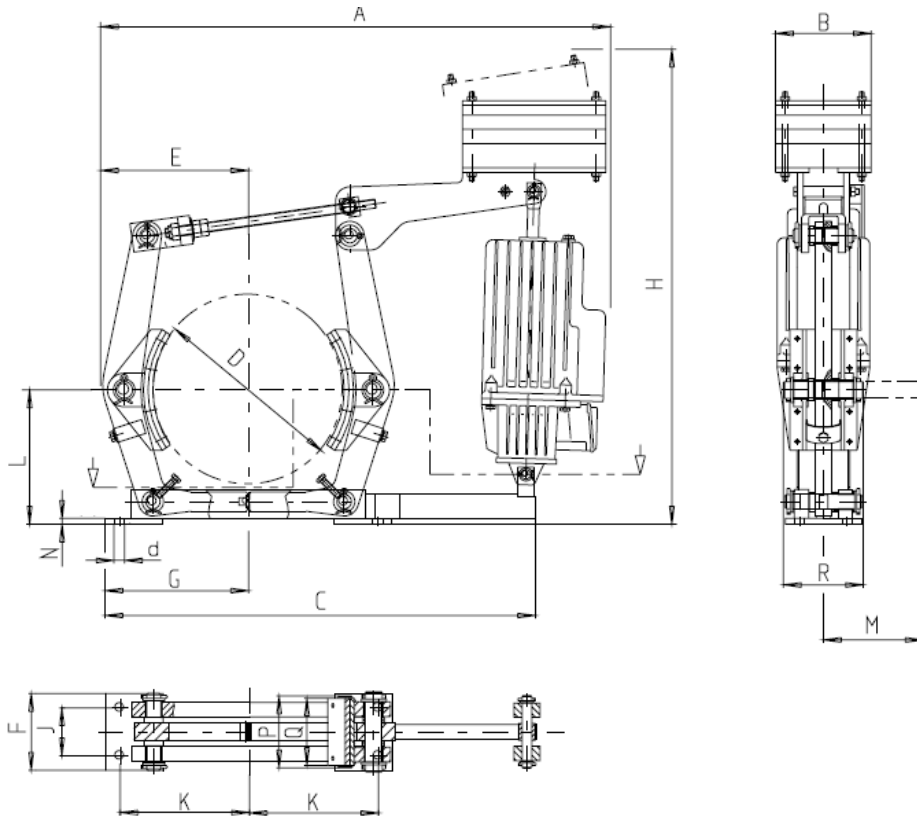

WHEN ORDERING
PLEASE ADVISE:

- brake type and thruster
e.g. SBG 250/23/5
- voltage and frequency for thruster
- with or without lining
wear compensator
- options (switches, manual
release lever, etc.)

THRUSTER SIZES

1 = Ed 23/5	10 = EB 220-50
2 = Ed 30/5	20 = EB 300-50
3 = Ed 50/12	30 = EB 500-120
4 = Ed 80/12	40 = EB 800-120
5 = Ed 121/12	50 = EB 1250-120
6 = Ed 201/12	60 = EB 2000-120
7 = Ed 301/12	70 = EB 3000-120

BRAKE-TYPE	Thruster SIZE	TORQUE RANGE in Nm at $\mu = 0,4$	A	B	C	D	E	F	G	H	J	K	L	M	N	P	Q	R	d	kg*
SBG 200	1 / 10	25 - 300	650	160	515	200	170	90	160	620	55	145	160	115	10	75	70	96	14	45
	2 / 20	25 - 400	650	160						660										50
SBG 250	1 / 10	40 - 325	750	160	625	250	210	110	200	680	65	180	190	133	10	95	90	113	18	57
	2 / 20	40 - 450	750	160						710										62
	3 / 30	100 - 850	785	195						835										82
SBG 315	1 / 10	70 - 420	880	160	735	315	260	125	240	770	80	220	230	160	10	118	110	135	18	66
	2 / 20	70 - 550	880	160						800										73
	3 / 30	75 - 1050	880	195						830										93
	4 / 40	90 - 1700	880	195						920										123
SBG 400	2 / 20	80 - 575	965	195	900	400	310	160	300	900	100	270	280	199	12	150	140	167	22	103
	3 / 30	100 - 1100	1005	195						940										123
	4 / 40	100 - 1800	1005	195						1000										153
	5 / 50	125 - 2750	1040	240						1050										195
SBG 500	3 / 30	200 - 1400	1185	220	1025	500	385	190	355	1040	130	325	340	242	13	190	180	202	22	173
	4 / 40	200 - 2200	1185	220						1090										203
	5 / 50	200 - 3400	1175	240						1180										243
	6 / 60	200 - 5400	1175	300						1230										323
SBG 630	5 / 50	500 - 3300	1330	240	1190	630	465	250	440	1300	170	400	420	295	15	236	225	244	27	347
	6 / 60	500 - 5500	1330	300						1350										427
	7 / 70	500 - 8200	1375	350						1350										527
SBG 710	5 / 50	500 - 3800	1465	240	1302	710	525	270	490	1400	190	450	470	332	15	265	255	276	27	380
	6 / 60	500 - 6300	1465	300						1450										460
	7 / 70	500 - 9400	1540	350						1450										560

* kg without thruster