

# DRUM BRAKE

## TPI

acc. to DIN 15435 | spring applied, thruster released

M 900 1600 E-EN-2003-02

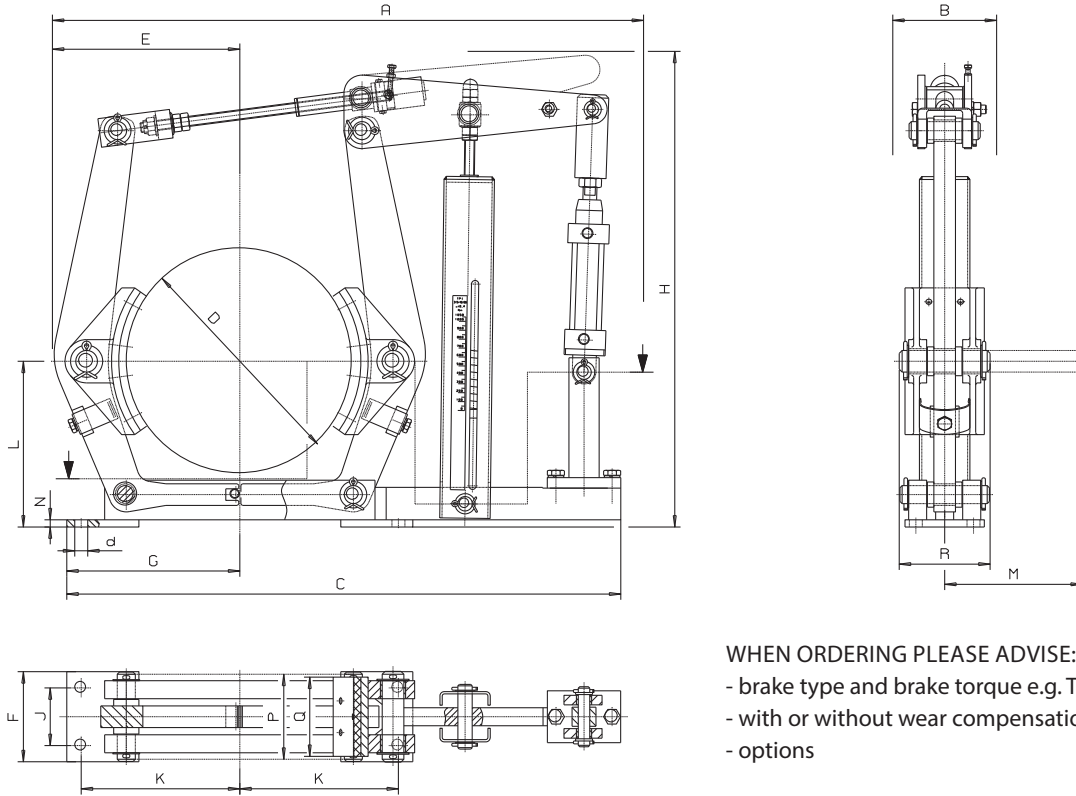

WHEN ORDERING PLEASE ADVISE:

- brake type and brake torque e.g. TPI 200/25/60
- with or without wear compensation
- options

Required pressure: 6 bar

BRAKE-TYPE	PNEUMATIC CYLINDER	MBR. (NM) TORQUE $\mu = 0,4$	A	B	C	D	E	F	G	H	J	K	L	M	N	P	Q	R	d	kg*
TPI 200	Ø 25/50	25 - 300	535	95	515	200	170	90	160	475	55	145	160	115	10	75	70	96	14	19
	Ø 32/50	25 - 400	540	95						475										
TPI 250	Ø 25/50	40 - 325	660	110	625	250	210	110	200	550	65	180	190	133	10	95	90	113	18	30
	Ø 40/80	100 - 850	665	110						560										
TPI 315	Ø 25/50	70 - 420	780	130	735	315	260	125	240	650	80	220	230	160	10	118	110	135	18	50
	Ø 32/50	70 - 550	780	130						650										
	Ø 40/80	75 - 1050	785	130						660										
	Ø 50/80	90 - 1700	790	130						660										
TPI 400	Ø 32/50	80 - 575	935	160	900	400	310	160	300	765	100	270	280	199	12	150	140	167	22	85
	Ø 40/80	100 - 1100	940	160						775										
	Ø 50/80	100 - 1800	945	160						775										
	Ø 63/80	125 - 2750	955	160						775										
TPI 500	Ø 40/80	200 - 1400	1090	200	1025	500	385	190	355	870	130	325	340	242	13	190	180	202	22	130
	Ø 50/80	200 - 2200	1095	200						870										
	Ø 63/80	200 - 3400	1100	200						870										
	Ø 80/80	200 - 5400	1110	200						870										
TPI 630	Ø 63/80	500 - 3300	1245	240	1190	630	465	250	440	1000	170	400	420	295	15	236	225	244	27	206
	Ø100/80	500 - 8200	1260	240						1000										
TPI 710	Ø 63/80	500 - 3800	1385	260	1302	710	525	270	490	1100	190	450	470	332	15	265	255	276	27	268
	Ø 80/80	500 - 6300	1390	260						1100										
	Ø100/80	500 - 9400	1400	260						1100										

\* kg without thruster