

TROMMELBREMSE

TPi

nach DIN 15435 | mit externer Bremsfeder und Pneumatikzylinder

M 900 1600 E-DE-2003-02

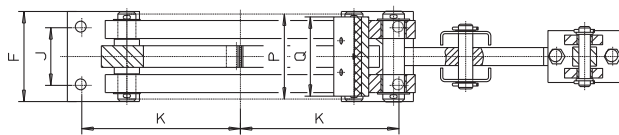
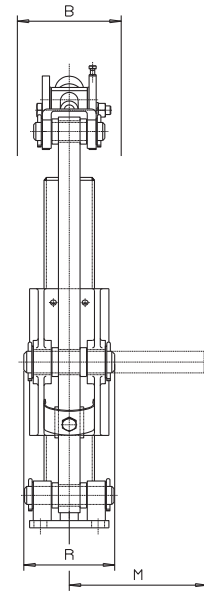
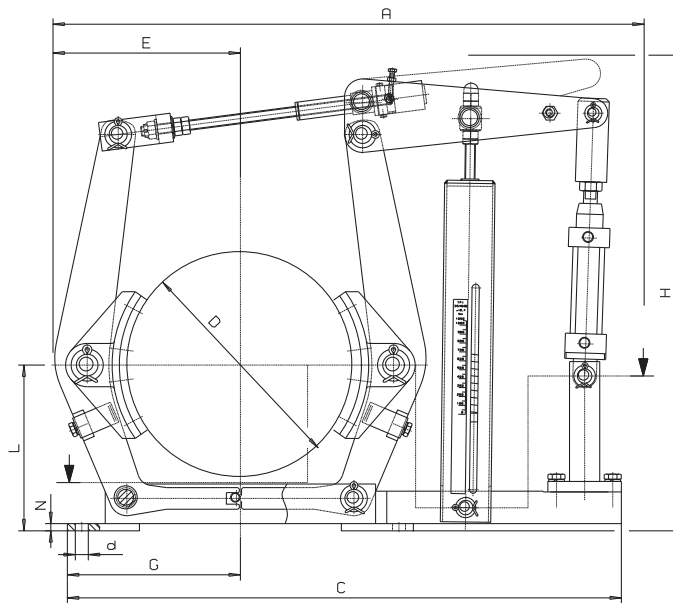

BEI BESTELLUNG BITTE ANGEBEN:

- Bremstyp und Pneumatikzylinder z.B. TPi 200/25/60
- mit oder ohne Verschleißnachstellung
- Zubehör

Erforderlicher Druck: 6 bar

Bremstyp	Pneumatikzylinder	Bremsmoment in Nm bei $\mu = 0,4$	A	B	C	D	E	F	G	H	J	K	L	M	N	P	Q	R	d	kg*
TPi 200	Ø 25/50	25 - 300	535	95	515	200	170	90	160	475	55	145	160	115	10	75	70	96	14	19
	Ø 32/50	25 - 400	540	95						475										
TPi 250	Ø 25/50	40 - 325	660	110	625	250	210	110	200	550	65	180	190	133	10	95	90	113	18	30
	Ø 40/80	100 - 850	665	110						560										
TPi 315	Ø 25/50	70 - 420	780	130	735	315	260	125	240	650	80	220	230	160	10	118	110	135	18	50
	Ø 32/50	70 - 550	780	130						650										
	Ø 40/80	75 - 1050	785	130						660										
TPi 400	Ø 50/80	90 - 1700	790	130	900	400	310	160	300	660	100	270	280	199	12	150	140	167	22	85
	Ø 32/50	80 - 575	935	160						765										
	Ø 40/80	100 - 1100	940	160						775										
	Ø 63/80	125 - 2750	955	160						775										
TPi 500	Ø 40/80	200 - 1400	1090	200	1025	500	385	190	355	870	130	325	340	242	13	190	180	202	22	130
	Ø 50/80	200 - 2200	1095	200						870										
	Ø 63/80	200 - 3400	1100	200						870										
	Ø 80/80	200 - 5400	1110	200						870										
TPi 630	Ø 63/80	500 - 3300	1245	240	1190	630	465	250	440	1000	170	400	420	295	15	236	225	244	27	206
	Ø 80/80	500 - 5500	1250	240						1000										
	Ø 100/80	500 - 8200	1260	240						1000										

* Kg ohne Lüftgerät